

FIELD STUDY ON THE REMOVAL OF SOLID IMPURITIES IN WASTEWATER TREATMENT PLANTS BY IMPLEMENTING A MODIFIED HYDROCYCLONE

**Thomas Senfter^{1,2*}, Benedikt Stern¹, Mathias Senn¹, Manuel Berger¹,
Martin Pillei³, Anke Bockreis², Wolfgang Rauch² and Michael
Kraxner¹**

¹MCI – The Entrepreneurial School, Environmental, Process & Energy Engineering,
Maximilianstraße 2, A-6020 Innsbruck, AUSTRIA; ²University of Innsbruck, Unit of
Environmental Engineering, Technikerstraße 13, A-6020 Innsbruck, AUSTRIA;

³Friedrich-Alexander-Universität Erlangen-Nürnberg (FAU), Institute of Fluid
Mechanics, Cauerstraße 4, D-91058 Erlangen, GERMANY

*Corresponding author: thomas.senfter@mci4me.at

For the optimization of biogas production in wastewater treatment plants often organic residues are added into the fermentation process. These residues may contain solid impurities such as glass, sand or metal particles. The advantage of an increased biogas yield is compensated by the disadvantage of increased erosion on the plant components caused by the impurities. For the removal of particles a modified hydrocyclone was investigated in previous studies in laboratory scale. Based on these results, hydrocyclones at industrial scales were installed and evaluated in a wastewater treatment plant. The present paper shows the optimum operational parameters for hydrocyclones with a separated impurity mass of 115 kg/d (average) and describes the potential of hydrocyclones as an add-on installation for the present application.

KEY WORDS: hydrocyclone, particle removal, purification, solid-liquid-separation, waste water treatment

NOTATION

d_a	Cyclone diameter (mm)
d_e	Inlet diameter (mm)
d_m	Diameter of the reference line (mm)
n	Experiment number (-)
u	Tangential velocity on the reference line (m/s)
z	Centrifugal acceleration (m/s ²)

1. INTRODUCTION

Co-fermentation is a common approach to improve the biogas output of municipal wastewater treatment plants (WWTP). Therefore, biological waste products are often used as a co-substrate which is added to anaerobic digesters (Bolzonella et al., 2006; Borowski,

2015). Commonly, the biological waste products are polluted by particulate impurities such as sand, glass or metal (Nowak and Ebner, 2016; Kranert et al., 2016). The negative effects of the impurities lead to increased erosion of plant components such as pumps or pipe elbows which lead to high operational costs of the plant operator (Novarino and Zanetti, 2012; Agyeman and Tao, 2014; Romera-Güiza et al., 2014; Jank et al., 2016). So there is the need for a system to remove the particles from the biological waste in order to reduce the operational costs at the WWTP.

Hydrocyclones are a promising device to allow for removal of particles and thus improve the co-fermentation process. Accordingly, previous studies were carried out to determine optimization potential in designing hydrocyclones for wastewater treatment plant applications. Therefore, optimized geometrical (see Figure 1) and operational parameters were investigated in more than 500 experiments between 2014 and 2018 (Senfter, 2019).

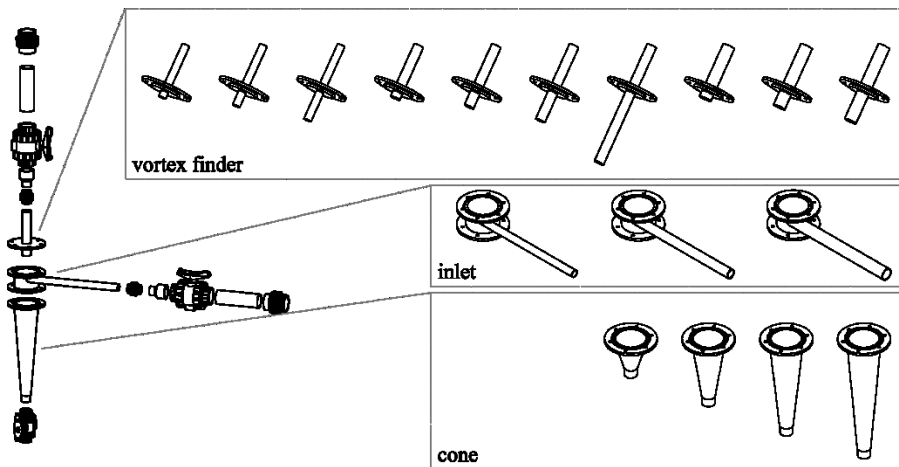

Figure 1. Previous study on the geometric parameters of a laboratory scale hydrocyclone with a diameter of $d_a = 100$ mm (Senfter, 2019)

Based on the previous optimization steps, hydrocyclones with an industrial scale ($d_a = 300$ mm) were installed in a WWTP. The evaluation of these hydrocyclones is the objective of this paper.

2. METHODS

The challenge to scale-up hydrocyclones is to deal with the conflicting priorities of centrifugal acceleration on a particle, the available pump performance and the dimensions of the site of installation. Figure 2 shows the simplified dimensions of the laboratory hydrocyclone and the field study hydrocyclone, where d_e is the inlet diameter, d_a the

cyclone diameter, d_m the diameter of the reference line in the inlet plane and u the tangential velocity on the reference line.

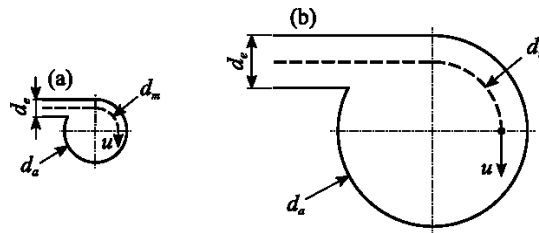

Figure 2. Simplified inlet plane of the laboratory scale hydrocyclone (a) with a diameter of 100 mm and the field study hydrocyclone (b) with a diameter of 300 mm (Senfter, 2019)

This allows the simplified determination of the centrifugal acceleration z on the reference line. The values are given in Table 1.

Table 1

Comparison of the operational parameters (Senfter, 2019)

Parameter	Laboratory hydrocyclone	Field study hydrocyclone
inlet flow rate	5 m ³ /h	106 m ³ /h
inlet velocity	2.26 m/s	3.75 m/s
inlet diameter	28 mm	100 mm
cyclone diameter	100 mm	300 mm
diameter of reference line	72 mm	200 mm
centrifugal acceleration	141 m/s ²	141 m/s ²

Figure 3 shows the field study hydrocyclones. For flexibility reasons the tests were implemented in a parallel arrangement of hydrocyclones, so the inlet flow rate is symmetrically split up into two units. By using slide valves, both cyclones can be operated individually.

The inlet flow rate of the hydrocyclones was limited by the existing circulation pumps of the anaerobic digester on the WWTP. The maximum flow rate for one hydrocyclone was 65 m³/h. The pressure drop was measured by two pressure sensors in the inlet and overflow of every hydrocyclone. The underflow was controlled by two underflow pumps with a maximum flow rate of 5 m³/h.

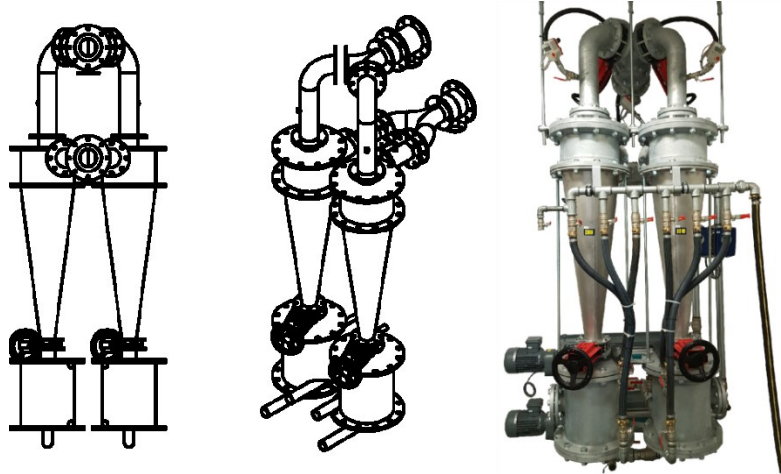

Figure 3. Field study hydrocyclones (Senfter, 2019)

The hydrocyclones were installed in the circulation pipe of an anaerobic digester (volume 1270 m³) supplied by two pumps in 1+1 operation mode. Figure 4 shows a simplified P&I-diagram for the test setup.

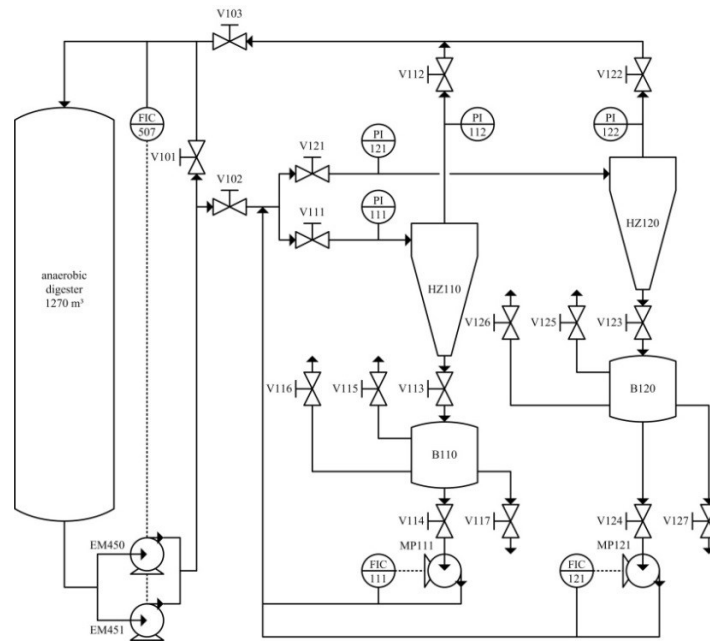

Figure 4. Simplified P&I-diagram for the setup of the test rig (Senfter, 2019)

The circulation pumps EM450 and EM451 are controlled by the flowmeter FIC507. Operational safety (maintaining the continuous circulation of the sludge in the anaerobic digester) can be guaranteed by the valves V101, V102 and V103. In case of malfunction of the hydrocyclone V101 will open and V102 and V103 will close. In normal operation mode V101 is closed and the digested sludge (incl. co-substrate) is pumped to the two hydrocyclones HZ110 and HZ120. The overflow of the hydrocyclone flows back to the circulation line of the anaerobic digester. The particle-rich underflow is transferred to the secondary separators B110 and B120. The underflow pumps MP111 and MP121 feed the purified sludge back to the circulation line. The secondary separators B110 and B120 are periodically flushed, using the valves V115, V116, V117 and V125, V126, V127. Table 2 shows the installed equipment.

Table 2

Product details of the installed equipment (Senfter, 2019)

part.nr.	Function	Details
V101, V102, V103	valve in circulation line	plate valves, DN150
HZ110, HZ120	hydrocyclone	parallel operation
B110, B120	secondary separator	equipped for flushing
MP111, MP121	underflow pump	Netzsch NEMO
FIC111, FIC121	flowmeter	Krohne OPTIFLUX 2050 C
PI111, PI112, PI121, PI122	pressure sensor	Honeywell Smartpress
V111, V121	inlet valve	plate valve, DN100
V112, V122	overflow valve	plate valve, DN100
V113, V123	underflow valve	plate valve, DN80
V114, V124, V117, V127	valves for the secondary separator	ball valve, DN50

The two main operational parameters inlet flow rate and underflow rate were varied according to Table 3. For the evaluation of the hydrocyclones the key performance indicator total separated particle mass (dried at 105°C) was recorded for all settings.

Table 3

Operational parameters for the experiments (Senfter, 2019)

Inlet flow rate per hydrocyclone in m ³ /h	Underflow rate per hydrocyclone in m ³ /h					
20	0	0.50	-	-	2	-
35	0	0.88	1.75	2.63	3.50	4.90
45	0	1.13	2.25	3.38	4.50	-
55	0	-	2.75	-	-	-
65	0	-	3.25	-	-	-

3. RESULTS AND DISCUSSION

The separated particle mass flow (dry) with an inlet flow rate of 20 m³/h was in a range between 0.05 and 0.1 kg/h for the different underflow rates and with 3 repetitions of every setting. In comparison, the separated particle mass at optimum settings was up to 6 kg/h. As the centrifugal acceleration is not sufficient for particle separation it was found that the hydrocyclone shall not be operated with an inlet flow rate of 20 m³/h.

For the higher inlet flow rates (35-65 m³/h) the total separated particle mass (dry) is shown in Figure 5. The error bars indicate the measured minimum and maximum values and the number of repetitions (*n*) for every setting is also displayed in the diagrams.

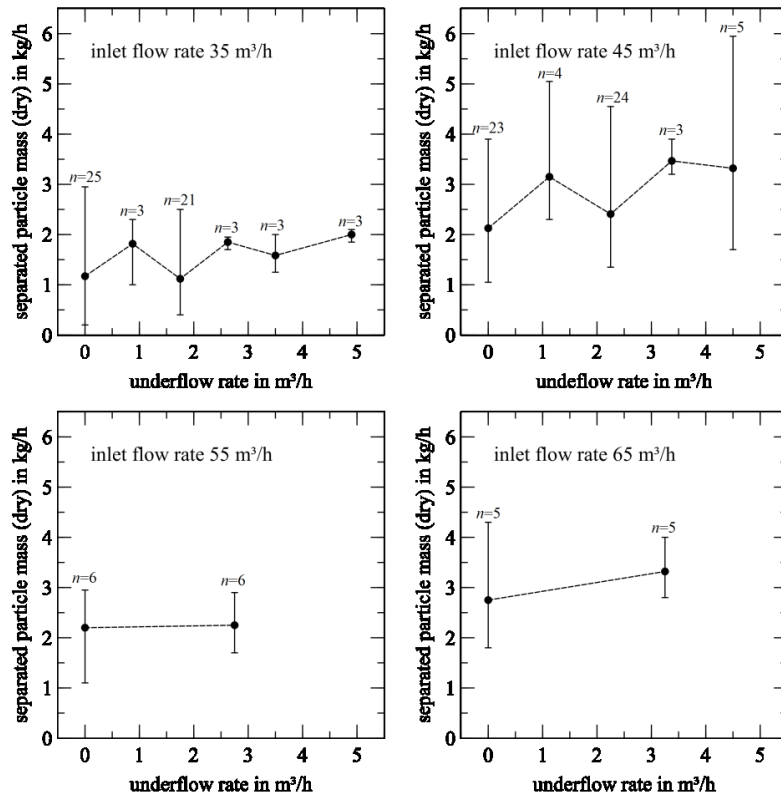

Figure 5. Total separated particle mass (dry) depending on the inlet flow rate and underflow rate (Senfter, 2019)

Increasing the inlet flow rate leads to a higher separated particle mass, while the influence of the underflow rate is negligible for performance. Increasing the inlet flow rate leads to increased pressure drop (high energy consumption). So the inlet flow rates 35 m³/h

and 45 m³/h are the preferred settings considering good particle separation and low energy consumption.

Therefore, a long term-experiment (1 month) for the inlet flow rates 35 m³/h and 45 m³/h was carried out to investigate time restrictions in the results. Thereby, also daytime, weekly and seasonal variation in the WWTP-process has been considered in the investigations. Figure 6 shows the results.

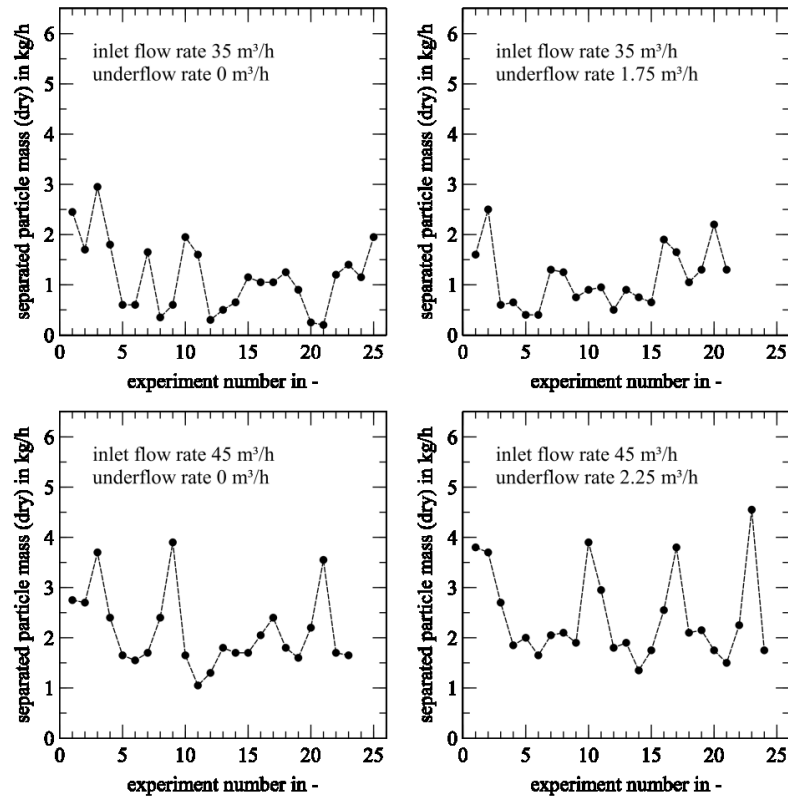

Figure 6. Total separated particle mass (dry) depending on the inlet flow rate and underflow rate in the long term experiments (Senfter, 2019)

After one month of hydrocyclone operation the total separated particle mass did not decrease. Averaging over the results of the inlet flow rate 45 m³/h and underflow rate 2.25 m³/h the total separated particle mass is 115 kg/d (41 tons/a). In conclusion, with an annual separated particle mass of 41 tons (assuming 365 days of operation), the hydrocyclone is a promising device for the removal of particulate impurities in the co-fermentation process. Moreover, the place of installation (circulation line of the anaerobic digester) and the use of already installed equipment (circulation pumps, flow meters) are strong benefits for a

hydrocyclone for this application. Thus, the installation of a hydrocyclone system can be recommended for WWTP operators.

ACKNOWLEDGEMENTS

The financial and personal support from MCI, BioTreaT GmbH, University of Innsbruck, hydro-IT GmbH, PORR Bau GmbH, HTL Anichstraße, HTL Bau und Design and six WWTPs (Zirl und Umgebung, Innsbrucker Kommunalbetriebe, Achental-Inntal-Zillertal, Pitztal, Telfs und Umgebung, Wörgl-Kirchbichl) is gratefully acknowledged. The dissertation was supported by the “Doktoratsstipendium der Stipendienstelle”, the “Doktoratsstipendium der Universität Innsbruck, Vizerektorat für Forschung” and the “Förderungsstipendium der Universität Innsbruck”.

REFERENCES

1. Agyeman, F.O., Tao, W., Anaerobic co-digestion of food waste and dairy manure: Effects of food waste particle size and organic loading rate, *Journal of Environmental Management*, 133, 268-274, 2014.
2. Bolzonella, D., Battistoni, P., Susini, C., Cecchi, F., Anaerobic codigestion of waste activated sludge and OFMSW: the experiences of Viareggio and Treviso plants (Italy), *Water Science and Technology*, 53, 203-211, 2006.
3. Borowski, S., Co-digestion of the hydromechanically separated organic fraction of municipal solid waste with sewage sludge, *Journal of Environmental Management*, 147, 87-94, 2015.
4. Jank, A., Müller, W., Waldhuber, S., Gerke, F., Ebner, C., Bockreis, A., Impurities in pretreated biowaste for co-digestion: A determination approach, *Waste Management*, 52, 96-103, 2016.
5. Kranert, M., Fritzsche, A., Böhme, A., Gottschall, R., Einflussgrößen auf die separate Bioguterfassung unter besonderer Berücksichtigung der Qualität (Influencing factors on the separate biowaste collection with special consideration of quality), 13. Recy & Depo Tech, 2016
6. Nowak, O., Ebner, C., Verwertung organischer Reststoffe in Faulbehältern kommunaler Kläranlagen (Utilization of organic residues in digesters of municipal wastewater treatment plants), *Österreichische Wasser- und Abfallwirtschaft*, 68, 108-117, 2016.
7. Novarino, D., Zanetti, M.C., Anaerobic digestion of extruded OFMSW, *Bioresource Technology*, 104, 44-50, 2012.
8. Romero-Güiza, M.S., Peces, M., Astals, S., Benavent, J., Valls, J., Mata-Alvarez, J., Implementation of a prototypical optical sorter as core of the new pre-treatment configuration of a mechanical-biological treatment plant treating OFMSW through anaerobic digestion, *Applied Energy*, 135, 63-70, 2014. anaerobic digestion, *Applied Energy*, 135, 63-70, 2014.
9. Senfter, T., Kontinuierliche Störstoffabtrennung in der Klärschlamm-Co-Fermentation mittels Zentrifugalabscheider (Continuous Removal of Impurities in Co-Fermentation Plants by using Centrifugal Separators), PhD-thesis, University of Innsbruck, 2019.